

BDT12 – Diaphragm type pressure gauge 100 & 160mm

Product description

Badotherm pressure gauge model BDT12 is a diaphragm type pressure gauge and suitable for all gaseous and liquid media, as well as for viscous media and suspended solids. This pressure gauge is typically used for applications in the chemical, petro-chemical, oil & gas, power and utilities, machine building and general process industries. These gauges can be made with threaded connections and flanged connections according ANSI, DIN, and JIS standards.

Design standard

EN837-3

Dial sizes, ranges & accuracy

Possibilities in ranges and accuracies are led by the dial size. Accuracy class is based on dry gauges. Liquid filling can affect the accuracy. Compound and vacuum ranges are possible as well based on the standard ranges

Dial size	Ranges	Accuracy
100mm	0...16 mbar to 0...250 mbar (flange Ø 160mm)	1.6%
160mm		
100mm	0...400 mbar to 0...25 bar (flange Ø 110mm)	1.6%
160mm		

Mounting variation

All BDT12 gauges are bottom connection type A.

- **type A** (13) bottom connection, direct mounting

Materials of construction

	BDT12
Case	AISI 304
Bezel	AISI 316
Process flange / lower part ¹	AISI 316
Sensing element ¹	AISI 316 (≥ 4 bar Duratherm)
Movement	Stainless steel
Pointer	Aluminium
Dial	
Window gasket	NBR
Blow out	
Fill plug	NBR (HNBR for filled gauges)
Flange gasket	FKM
Window	Glass

¹ wetted materials



Process connection

Threaded version

Standard thread	optional
G ½ A or ½" NPT	G ½ or ½" NPT-f

Other thread standards such as ISO 7-1 R (BSPT), or DIN 13-1 (M20x1.5) can be selected as well. Due to the weight of the assembly a ¼" thread is not advised.

-> See datasheet "thread information" for specific thread details

Flanged version

ASME B16.5			
Size	Rating	Facing	Roughness
0.5" to 2"	cl.150 - cl.300	RF, LMF, FF, SGF	Ra 3.2-6.3 µm
		RJF, SFF	Ra <1.6 µm
		SMF, LTF, STF, LGF, LFF	Ra <3.2 µm

EN 1092-1			
Size	Rating	Type	Roughness
DN20 to DN50	PN10-40	A, B1, E, F	Ra 3.2-12.5 µm
		B2, C, D, G, H	Ra <0.8-3.2 µm

Pressure limitations

The pressure gauges are built to withstand harsh environments however the EN 837-3 limits the use of a pressure gauge according below table.

Dial size	Steady	Fluctuating	Short time
100mm /160mm	FSV	0.9 x FSV	1.25 x FSV

FSV: full scale value

range	standard	Option 1	Option 2	Type 5
16 mbar	5x FSV	10x FSV	5 bar	-
25 mbar				
40 mbar				
60 mbar				
100 mbar				
160 mbar				
250 mbar	1.25x FSV	5x FSV	10 bar	40 bar
400 mbar				
600 mbar				
1.0 bar				
1.6 bar				
2.5 bar		40 bar		
4.0 bar				
6.0 bar				
10 bar				
16 bar				
25 bar				

Temperature limitations

The gauges can withstand ambient and process temperature up to a certain limit. The limitations on temperature are:

	Ambient	Medium	Storage
Dry case	-20°C ...+60°C	-20°C...+100°C	-40...+70°C
Filled case	-20°C ...+60°C	-20°C...+90°C	

The variation of indication caused by the effect of temperature shall not exceed: $\pm 0.8\% / 10K FSV$

Window

Standard BDT12 gauges have a glass window. Optionally it can be selected with laminated safety glass or plastic

Pointer

Standard pointer is a slotted black painted aluminum pointer and optionally with a micro adjustable pointer

Dial facing

The dial plate is made from aluminum and coated with UV resistant white coating. The black dial markings, scale, numbering, and interval is according the EN 837. Options like colored dial, customer logo, or colored segments are possible as well. Scale interval and numbering is following the EN837.

Degree of protection

The BDT12 has a standard degree of protection of IP65. The values are determined according the IEC/EN 60529.

Add-on contacts

The BDT12 can be equipped with an add-on contact mounted in a Makrolon hood. For low pressures <100 mbar inductive contacts are advised.

Case filling

The gauges can be filled with different kind of fill fluids. The fill fluids available are:

- BPF01 - Glycerine 86%
- BPF02 - Silicon
- BPF03 - Silicon for contacts
- BPF04 - Mineral oil (Foaming service)
- BPF05 - Halocarbon (inert fluid for oxygen service)

Special service

The gauges can be supplied cleaned for oxygen use. This means the gauge is assembled and tested in a special area free of oil. The gauges are individually packed in a plastic bag with marking. The symbol used is:



Certification & Declaration

Calibration

Gauges are full range calibrated as a factory standard. Optionally you can select a 5 points calibration certificate

[ATEX 114 - 2014/68/EU](#)

ATEX restrictions are explained in the IOM and in the ATEX background datasheet.

[EN 10204 material certificate](#)

A material 3.1 certificate on the wetted parts can be supplied.

Retaining bolts & nuts

The retaining bolts between upper and lower part are made of A4-70 (AISI316) material.

Size	Grade bolt	Grade nut	Material
M6 (≤250 mbar)	ISO 3506-1 A4-70	ISO 3506-2 A4	AISI 316

Torque

The closing between upper part and lower part is done with retaining bolts. The torque of the bolts is 10 Nm (7.3 ft-lb).

Gaskets

For the BDT12 a gasket is supplied for the closing between the upper and the lower part. The standard flange gasket is FKM (Viton) material. Depending on the chemical compatibility the option of NBR or EPDM can be selected as option.

Material	Operating temperature
FKM ◀	-40 / +108°C
NBR	-25 / +204°C
EPDM	-55 / + 150°C

◀: Standard gasket

Wetted part and diaphragm combinations

The BDT12 can be selected with process flanges in exotic materials or coatings. The diaphragm can be executed with a exotic material protection sheet as well. Applying protection sheets will have consequences for the accuracy of the gauge.

Flange + connection	Diaphragm material		
	General name	UNS	Wst.
AISI 316(L)	AISI 316L	S31603	1.4404
	Alloy C276	N27600	2.4810
	PTFE Sheet	-	-
Alloy 400	Alloy 400	N04400	2.4360
Alloy C-276	Alloy C-276	N10276	2.4810
PTFE lining	Tantalum	R05200	

Polymer solutions

Polymer solutions come in several executions and forms. The technical data on thickness and temperature limitation can be found in datasheet "polymer solutions". The diaphragm of the BDT12 can be treated with the below coatings or sheet. Sheets cannot be used with application with vacuum pressures.

- PTFE coating
- ECTFE (Halar®) coating
- PFA coating
- FEP coating
- PTFE sheet

The lower part of the BDT12 flanged can be executed with:

- PTFE coating
- PFA coating
- PTFE lining

Lining on threaded versions is not advised. G ½" A is possible in combination with a rotating process nut to prevent damage to the lining

Dimensions table threaded

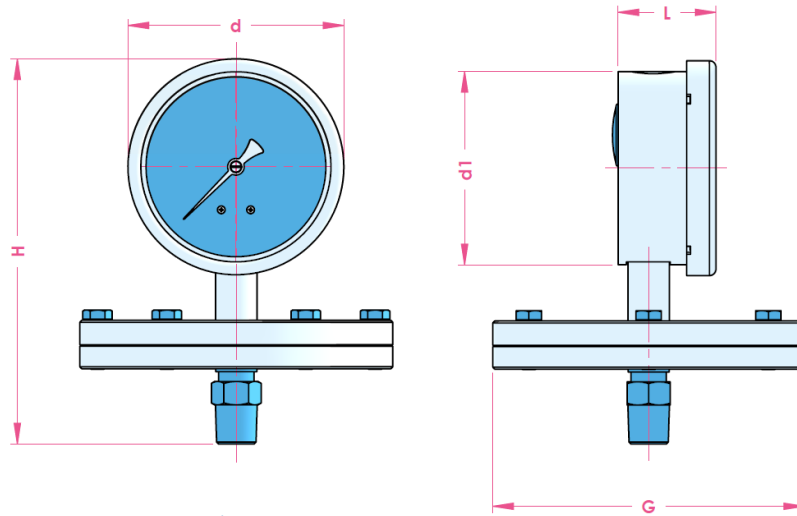

BDT12 – 25...400 mbar

Dial size	d	d1	L	H	G	SW	weight
100	110.0	100.0	50.0	200.0	160.0	22	1.8 kg
160	160.0	149.0	52.0	250.0			2.1 kg

BDT12 – 0.6...25 bar

Dial size	d	d1	L	H	G	SW	weight
100	110.0	100.0	50.0	200.0	108.0	22	1.6 kg
160	160.0	149.0	52.0	250.0			1.9 kg

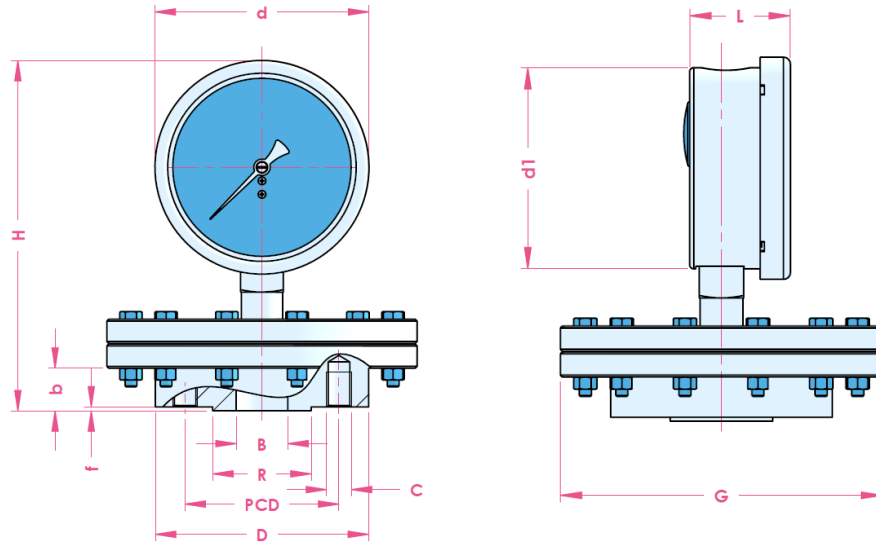

BDT12 gauge sizes

Dial size	d	d1	L
100	110.0	100.0	50.0
160	160.0	149.0	52.0

ASME B16.5 size table for flanged connection

size	rating	D	G	B	b	R	f	H	PCD	C / pcs	Weight
1/2"	cl. 150	90.0	160.0	15.8	36.0	34.9	2.0	176.0	60.3	0.5" - 13 UNC / 4x	+/- 8 kg
	cl. 300	95.0						66.7			
3/4"	cl. 150	100.0		179.0	69.9	0.5" - 13 UNC / 4x					
	cl. 300	115.0		184.0	82.6	5/8" - 11 UNC / 4x					
1"	cl. 150	110.0		178.0	79.4	0.5" - 13 UNC / 4x					
	cl. 300	125.0		181.0	88.9	5/8" - 11 UNC / 4x					
1.5"	cl. 150	160.0		190.0	98.4	0.5" - 13 UNC / 4x					
	cl. 300			190.0	114.3	3/4" - 10 UNC / 4x					
2"	cl. 150	165.0	169.0	120.7	5/8"-11 UNC / 4x						
	cl. 300		170.0	127.0	5/8"-11 UNC / 8x						

DIN 1092-1 size table for flanged connection

size	rating	OD	B	b	R	f	H	PCD	C / pcs	Weight
DN15	PN10-40	140.0	17.3	40.0	45.0	2.0	67.0	65.0	M12 / 4x	+/- 8 kg
DN20	PN10-40		22.3	38.0	58.0		65.0			
DN25	PN10-40		28.5	35.5	68.0		62.5			
DN40	PN10-40	150.0	43.1	40.0	88.0	3.0	78.0	110.0		
DN50	PN10-40	165.0	54.5	30.0	102.0		58.0		125.0	

Product code 100, 160mm

	Code											
Example code:	BDT12	160	A	G12M	S363	S316	S304	A	0	G	P48	16
TYPE												
100 mm ◀	100											
160 mm ◀	160											
MOUNTING												
Bottom connection - direct mounting (13) ◀	A											
CONNECTION												
G1/2 ◀	G12M											
1/2" NPT	N12M											
R 1/2	R12M											
M20 x 1.5	M20M											
Flanged (see table 6)	-											
SENSING ELEMENT												
AISI 316 (>4 bar Duratherm) ◀	S363											
Alloy 400 *1	A400											
Alloy C276*1	A276											
Tantalum *1	TA52											
PTFE sheet*1	SPTF											
PROCESS FLANGE (LOWER PART)												
AISI 316(L) ◀	S316											
Alloy 400	A400											
Alloy C276	A276											
AISI316(L) PTFE lined*2	LPTF											
CASE/BEZEL MATERIAL												
AISI 304 ◀	S304											
AISI 316	S300											
POINTER												
Adjustable slotted pointer ◀	A											
Micro adjustable pointer	M											
Add-on contact device (see table 7)	A__											
LIQUID FILLING												
Dry ◀	0											
BPF 01 - Glycerine filled 1,23 (86%)	1											
BPF 02 - Silicone filled	2											
BPF 03 – Silicone Contact use	3											
BPF 04 – Mineral oil (Foaming service)	4											
BPF 05 – Halocarbon (Oxygen service)	5											
WINDOW												
Glass ◀	G											
Laminated safety glass	L											
Acrylic (SAN)	A											
RANGE												
See page table 1 and table 2											
ACCURACY												
1,6 ◀	16											

◀: is the sign for the standard pressure gauge.

1: Based on protection sheet. Use of protection sheet leads to a lower accuracy class up to class 2.5. Sheet is not possible for application with vacuum.

2: Not possible for NPT thread, G thread only in combination with rotating nut as process connector

Tabel 1: Pressure Range code

bar		mbar		psi		kPa		kgf/cm2	
Code	Range	Code	Range	Code	Range	Code	Range	Code	Range
C36	-1...0,6	C20B	-10...15	C37	30Hg/15psi	D36	-100...60	E36	-1...0,6
C38	-1...1,5	C21A	-10...30	C39	30Hg/30psi	D38	-100...150	E38	-1...1,5
C40	-1...3	C22A	-10...50	C41	30Hg/60psi	D40	-100...300	E40	-1...3
C42	-1...5	C21C	-20...20	C44	30Hg/100psi	D42	-100...500	E42	-1...5
C45	-1...9	C22B	-20...40	C46	30Hg/150psi	D45	-100...900	E45	-1...9
C50	-1...15	C22C	-30...30	C50	30Hg/220psi	D50	-100...1500	E50	-1...15
C54	-1...24	C24C	-40...60	C53	30Hg/300psi	D54	-100...2400	E54	-1...24
B01	-1...0	C24D	-50...50	P32	0...15	L01	-100...0	K01	-1...0
B04	-0,6...0	C27B	-100...150	P35	0...25	L04	-60...0	K04	-0,6...0
B31	0...0,6	M19	0...16	P37	0...35	L31	0...60	K31	0...0,6
B35	0...1	M20	0...25	P40	0...60	L35	0...100	K35	0...1
B36	0...1,6	M21	0...40	P43	0...100	L36	0...160	K36	0...1,6
B38	0...2,5	M22	0...60	P46	0...150	L38	0...250	K38	0...2,5
B40	0...4	M24	0...100	P48	0...250	L40	0...400	K40	0...4
B42	0...6	M25	0...160	P51	0...350	L42	0...600	K42	0...6
B45	0...10	M27	0...250			L45	0...1000	K45	0...10
B50	0...16	M29	0...400					K50	0...16
B54	0...25	M31	0...600					K54	0...25

Table 2: Secondary scale

Dual scale option	code
PSI red	#PR
PSI black	#PB
PSI blue	#PBL
bar red	#BR
bar black	#BB
bar blue	#BBL

Add the code behind the pressure code
(eg B45#PR for 0...10 bar//psi with red scale)

Table 3: General option code

Option (start options with X_)	code
IP 65 class	_IP65
IP 67 Class	_IP67
Cleaned for Oxygen use	_CFO
NACE ISO 15156 (MR 01 75) (alloy 400)	_N75
ATEX II 2G Ex h IIC	_ATEX
3.1 material certificate	_IC31
Calibration certificate 5 points **	_CC5
Adjusting key for contact	_AKC
Lead cable + Adjusting key for contact	_LCK
5x over pressure safe	_05X
10x over pressure safe	_10X
5 bar over pressure safe	_05B
10 bar over pressure safe	_10B
40 bar over pressure safe	_40B

1: excluding contact device and case filling

Table 4: Coating options

Option	code
PTFE Coating on Process connection	CPTF
PFA Coating on Process connection	CPFA

Table 5: Gasket options

Option	code
NBR gasket between process flanges	NB
EPDM gasket between process flanges	EP

Table 6: Flange size

ASME B16.5

Flange size	code
0,5"	01
0,75"	1A
1"	02
1,25"	03
1.5"	04
2"	05

Flange Class	code
cl. 150	A1
cl. 300	A2

EN 1092-1

Flange size	code
DN10	21
DN15	22
DN20	23
DN25	24
DN32	25
DN40	26
DN50	27

Flange size	code
PN 10-40	D4

Facing	Code ASME	Code EN	
Raised Face	RF	B1	B2
Flat Face	FF	A	
Ring Joint Face	RJF	-	
Large Male Face	LMF	E	
Small Male Face	SMF	-	
Large Tongue Face	LTF	C	
Small Tongue Face	STF	-	
Large Groove Face	LGF	D	
Small Groove Face	SGF	-	
Large Female Face		F	
Small Female Face		-	

When configuring a flange combine the first two digits and the last two digits. EG: 2" 150# RF ASME connection is 05A1RF

Table 7: Contact option code

Option (start options with X_)	code	
Snap-action magnetic contact*	M1 (make contact)	_AM1
	M2 (break contact)	_AM2
	M11 (make - make contact)	_AM11
	M12 (make - break contact)	_AM12
	M21 (break - make contact)	_AM21
	M22 (break – break contact)	_AM22
Inductive contact	I1 (make contact)	_AI1
	I2 (break contact)	_AI2
	I11 (make - make contact)	_AI11
	I12 (make - break contact)	_AI12
	I21 (break - make contact)	_AI21
	I22 (break – break contact)	_AI22

<100 mbar only Inductive contact possible. Accuracy BDT12 is excluding contact
 Contacts are without cable and adjusting key.

Change log

Date	Change
9-6-2020	Added tables for facing in coding section.

Holland – Romania – India – Thailand – Dubai – USA

To our knowledge, the information contained herein is accurate as of the date of this document. However neither Badotherm, nor its affiliates makes any warranty, express or limited, or accepts any liability in connection with this information or its use. This information is for technical skilled persons at their own discretion and risk and does not relate to the use of this product in combination with any other product. The user alone finally determines suitability of any information or material in contemplated use, the manner of use and whether any patents are infringed. This information gives typical properties only. Badotherm reserves the right to make changes to the specifications any materials without prior notice. The latest version of the datasheet can be found on www.badotherm.com.

© 2015 Badotherm, all rights reserved. Trademarks and/or other products referenced herein are either trademarks or registered trademarks of Badotherm.